

# Design of a Novel Ring Current Controlled Oscillator with low Phase Noise and High frequency range Using Nanowire Transistor

M. Khalaj

Department of Electronics Department of Azad University of kazerun Branch, kazerun, Fars, Iran

\*Corresponding Author: mansour.khalaj91@yahoo.com

Available online at: www.ijcseonline.org

Received: 12/Jan/2017

Revised: 23/Jan/2017

Accepted: 18/Feb/2017

Published: 31/Mar/2017

**Abstract**— In this paper a ring CURRENT CONTROLLED OSCILLATOR with high frequency range and low phase noise in Nanowire transistor technology is presented. In the proposed CURRENT CONTROLLED OSCILLATOR, two techniques including control of current and body bias technique is implemented to increase the range of frequency. It is proved that body bias of control transistor cause to increase the frequency range noticeably. Moreover, by adding an inductor in the body of control transistor, the phase noise is decreased as well. The phase noise in 1 MHz offset frequency is -90 dBc/Hz and the frequency range is 2-14 GHz.

**Keywords**— Current Controlled Oscillator, Ring, Phase Noise, Frequency Range

## I. INTRODUCTION

PLL (Phase Locked Loop) has a lot of applications in communication and wireless systems[1]. It can be used for many systems like as time generation and synchronization circuits in digital integrated circuits as well as demodulation and phase detection in analog circuits [1]. Figure 1 shows the phase locked loop circuit block diagram. The most important part in a Phase Locked Loop is oscillator that can be implemented using LC or ring oscillators [2, 3].

LC oscillators have smaller capacitor and inductor [4] causing usually have low quality factor. The low quality factor leads to narrow tuning range and large phase noise. Therefore, LC oscillators are mostly used in high phase noise and narrow tuning range applications[5]. Furthermore, large spiral inductors consume a large chip area that is not desirable for integration.

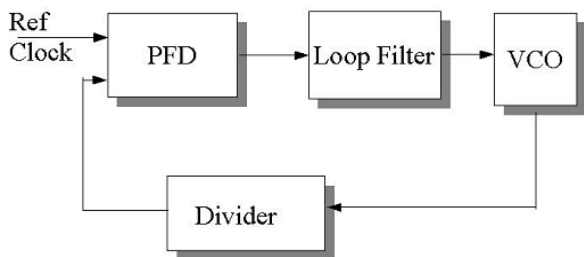

Figure1. A typical PLL circuit block diagram

Ring voltage controlled oscillators (RCURRENT CONTROLLED OSCILLATOR) have lower phase noise than LC oscillators and because of the wide tuning range, they are used in PLL circuits. Moreover, because of smaller chip area comparing to LC oscillators, it is easier to integrate

them in a CMOS technology. A ring oscillator consists of multiple gain stages (delay cells) in a loop [4,6] as shown in Figure 2. Different delay cells have been compared in terms of different parameters such as tuning range, power dissipation and phase noise. The delay cells can be differential or single-ended units.

Differential configuration is more common because of common mode noise rejection capability, but uses larger chip area and consume more power[3]. The challenges in the RCURRENT CONTROLLED OSCILLATOR design are to achieve linearity of frequency modulation, low voltage and power Consumption, low phase noise and wide frequency range [7].

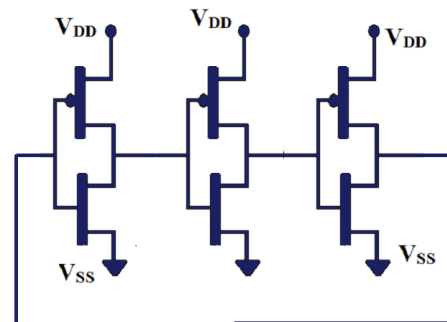

Figure 2 A ring oscillator consists of multiple delay cells

A single-ended oscillator should contain odd number of delay/gain stages with  $\pi/n$  delay value for each stage in a feedback loop [8]. Most reported designs use single ended or differential configuration using current

controlled (CC) or voltage controlled (VC) technique as shown in figure 3[4,9].

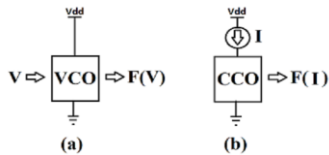

Figure 3. (a) voltage-controlled oscillator. (b) current-controlled oscillator [9]

A typical Ring CURRENT CONTROLLED OSCILLATOR is plotted in Figure 4. In this design, the voltage control Vc is used to control the frequency of oscillator.

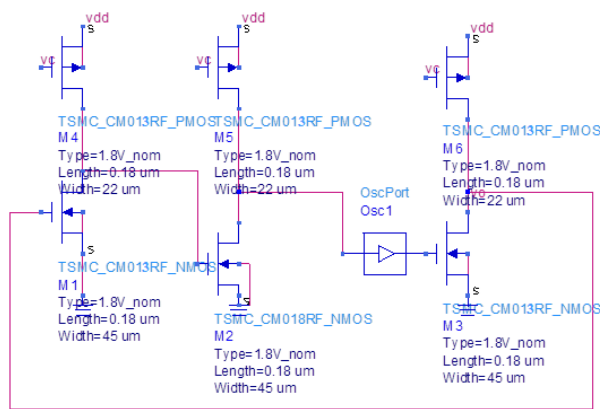

Figure 4. A typical Ring CURRENT CONTROLLED OSCILLATOR

In this paper the current controlled method with body biasing technique have been used to decrease the threshold voltage  $V_{th}$  and improve the RCURRENT CONTROLLED OSCILLATOR performance. Single-ended circuit has been simulated to present the concept, even though, the method can be extended to differential pair configuration.

This paper has been structured as follows, section 2 describes RCURRENT CONTROLLED OSCILLATOR circuit design, transistor sizing and oscillation frequency. Simulation and analysis of the circuit are in section 3. Concluding remarks are at the end.

**II. PROPOSED TOPOLOGY**

The method used here is based on changing bulk voltage to change the current of oscillator and so the wider range of gate voltage control could be achieved.

In this paper the three stage oscillator with control of current method is used. Increasing the number of stages can cause to decrease the frequency of oscillation and increase of power consumption. Figure 5 shows one stage of ring oscillator. In this design the body of control transistor is biased to increase

the range of current variations. The bulk voltage of the PMOS transistor should be controlled in a way that the bulk-source junction remains in reverse or slightly into forward bias. To guarantee this the bulk-source junction will not go into forward bias more than 0.5V, so the bulk current will remain negligibly low [5, 10-16]. An extra transistor M10 has been used to better control the bulk voltage and reduce loading effects on the control voltage as shown in Figure 5.

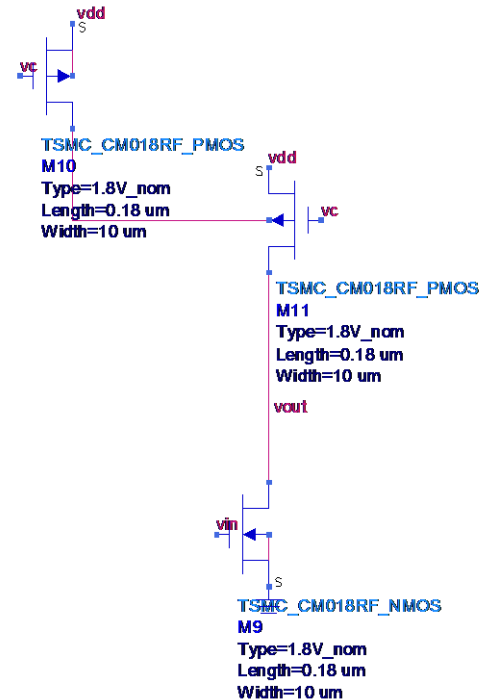

Figure 5 one stage of ring oscillator

Figure 6 shows the drain voltage versus gate voltage of one stage delay cell for  $V_c=0.5V$

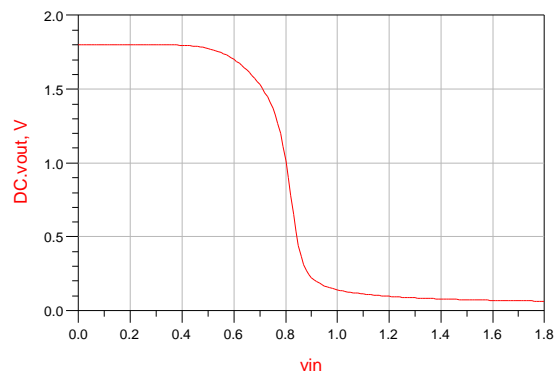

Figure 6 the drain voltage versus gate voltage

Figure 7 shows the three stage oscillator. The frequency of this oscillator is as follows:

$$f_{osc} = \frac{1}{6C_{load} V_{DSn}} \left( \frac{1}{2} K_p \left( \frac{W}{L} \right)_p (V_{DD} - V_{in} - |V_{THp}|)^2 \right) \quad (1)$$

$$|V_{THp}| = |V_{TH0p}| + \gamma \left( \sqrt{2|\Phi_f| - V_{sb}} - \sqrt{2|\Phi_f|} \right) \quad (2)$$

This equation shows that the oscillation frequency is decreased by increasing the control voltage.

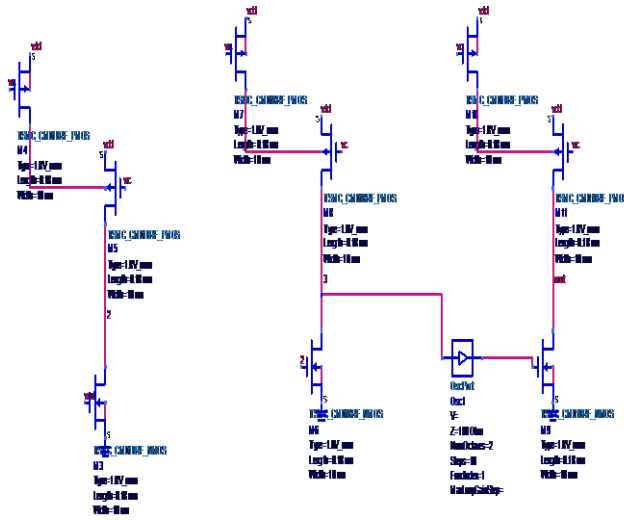

Figure 7 the three stage oscillator

The simulation results of this circuit is shown in figure 8 for Vc=0.5 V. in this state the oscillation frequency is 7.14 GHz.

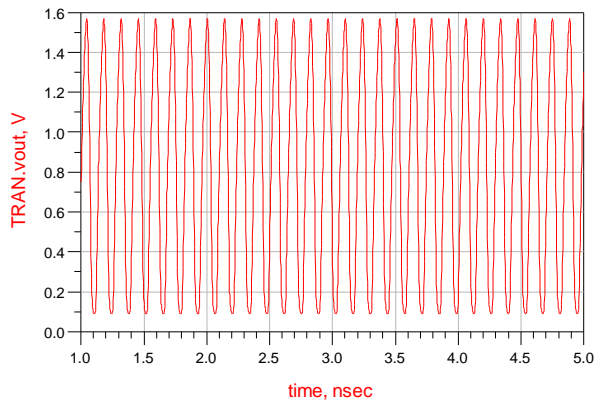

Figure 8. The simulation results of CURRENT CONTROLLED OSCILLATOR for Vc=0.5 V

The oscillation frequency as a function of voltage control is plotted in figure 9. As voltage control is changed from 0 to 1 v, the frequency is changed from 1.75 GHz to 11 GHz.

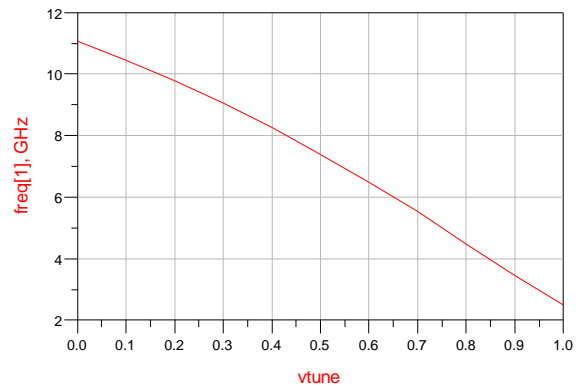

Figure 9. The oscillation frequency as a function of voltage control

The phase noise of this oscillator for Vc=0.5 V is plotted in Figure 10. One can see that the phase noise of this oscillator in this state is -82.5 dBc/Hz.

m1  
noisefreq=1.002MHz  
pnmx=-82.57 dBc

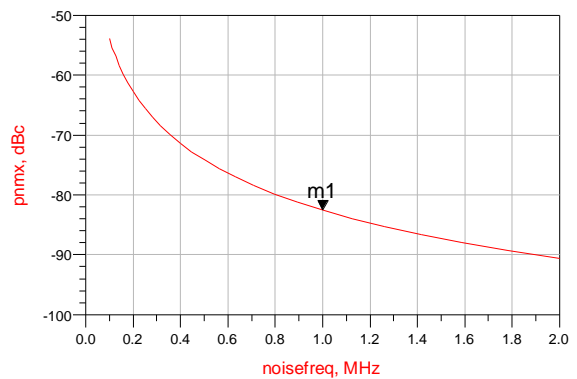

Figure 10. The phase noise of this oscillator for Vc=0.5 V

To improve the performance of proposed oscillator, an inductor is added in the bulk of control transistor. The proposed oscillator is shown in figure 11. Figure 12 shows the frequency range of proposed oscillator. One can see that the frequency range of proposed oscillator is increased by 3 GHz. The phase noise of proposed oscillator is shown in figure 13. One can see that the phase noise of proposed oscillator is improved noticeably. Table 1 shows the results of proposed oscillator.

III. CONCLUSION

In this paper, a novel ring oscillator is proposed and simulated in Nanowire Transistor technology. To increase the frequency range of oscillator a novel technique based on body bias technique of control transistor is proposed. Moreover, an inductor is added to the bulk of control transistor to improve its performance. It is proved that by using inductor the frequency range and phase noise is improved simultaneously. The phase noise of proposed oscillator was -90 dBc/Hz and the frequency range was 2-14 GHz.

References

- [1] M.-L. Sheu, Y.-S. Tiao, L.-J. Taso, "A 1-V 4-GHz wide tuning range voltage-controlled ring oscillator in 0.18 $\mu$ m CMOS," *Microelectronics Journal*, vol. 42, pp. 897-902, 2011.
- [2] J. Zhao and Y.-B. Kim, "A low-power digitally controlled oscillator for all digital phase-locked loops," *VLSI Design*, vol. 2010, p. 2, 2010.
- [3] W.-H. Lee, B.-J. Gu, Y. Nishida, H. Takao, K. Sawada, M. Ishida, "Oscillation-controlled CMOS ring oscillator for wireless sensor systems," *Microelectronics Journal*, vol. 41, pp. 815-819, 2010.
- [4] M. Frankiewicz and A. Kos, "Wide-frequency-range low-power variable-length ring oscillator in UMC CMOS 0.18  $\mu$ m," in *Mixed Design of Integrated Circuits and Systems (MIXDES)*, 2013 Proceedings of the 20th International Conference, 2013, pp. 291-293.
- [5] T. Li, B. Ye, J. Jiang, "0.5 V 1.3 GHz voltage controlled ring oscillator," in *ASIC, 2009. ASICON'09. IEEE 8th International Conference on*, 2009, pp. 1181-1184.
- [6] U. Guler and G. Dundar, "Modeling CMOS Ring Oscillator Performance as a Randomness Source," *IEEE Transactions on Circuits and Systems I: Regular Papers*, vol. 61, pp. 712- 724, 2014.
- [7] T. V. Cao, D.T. Wisland, T.S. Lande, F. Moradi, "A bulk-controlled ring-CURRENT CONTROLLED OSCILLATOR with 1/f-noise reduction for frequency  $\Delta\Sigma$  modulator," in *Mixed Design of Integrated Circuits & Systems, 2009. MIXDES'09. MIXDES-16th International Conference*, 2009, pp. 187-192.
- [8] A. Ramazani, S. Biabani, GH. Hadidi, "CMOS Ring Oscillator with Combined Delay Stages," *AEU-International Journal of Electronics and Communications*, 2014.
- [9] P. Nugroho, R.K. Pokharel, H. Kanaya, K. Yoshida, "A 5.9 GHz Low Power and Wide Tuning Range CMOS Current-controlled Ring Oscillator," *International Journal of Electrical and Computer Engineering (IJECE)*, vol. 2, pp. 293-300, 2012.
- [10] J. Radic, A. Djugova, L. Nagy, M. Videnovic-Misic, "Body effect influence on 0.18  $\mu$  m CMOS ring oscillator performance for IR-UWB pulse generator applications," in *Embedded Computing (MECO), 2012 Mediterranean Conference on*, 2012, pp. 170-173.
- [11] J. Garg and S. Verma, "Design of low power Voltage Controlled Oscillator," in *Emerging Technology Trends in Electronics, Communication and Networking (ET2ECN)*, 2012 1st International Conference on, 2012, pp. 1-4.
- [12] R. Ashish, J.N. Vashishtha, R K sarin, "A RF Low Power 0.18- $\mu$  m based CMOS Differential ring oscillator," *Proceedings of the World Congress on Engineering*, vol. 2, 2012.
- [13] S.-M. Kang and Y. Leblebici, *CMOS digital integrated circuits: Tata McGraw-Hill Education*, 2003.

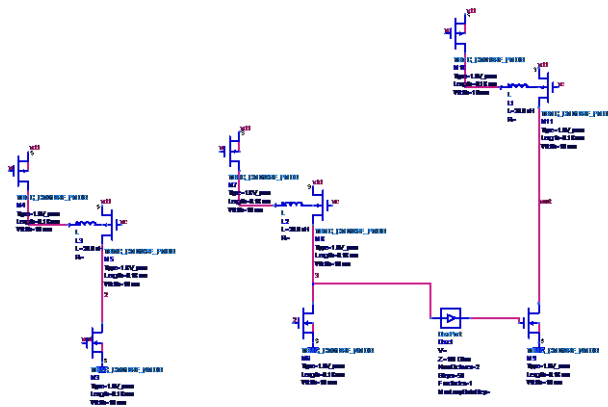

Figure 11. The proposed oscillator

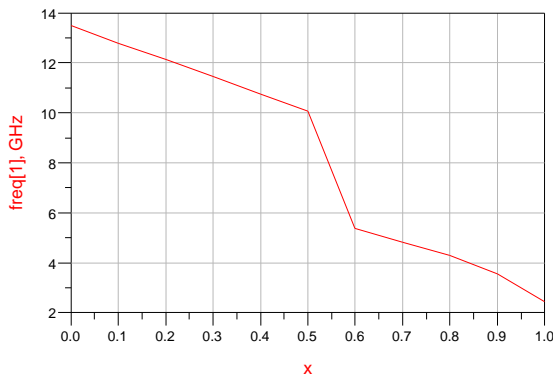

Figure 12 the frequency range of proposed oscillator.

m1  
noisefreq=1.002MHz  
pnmX=-89.98 dBc

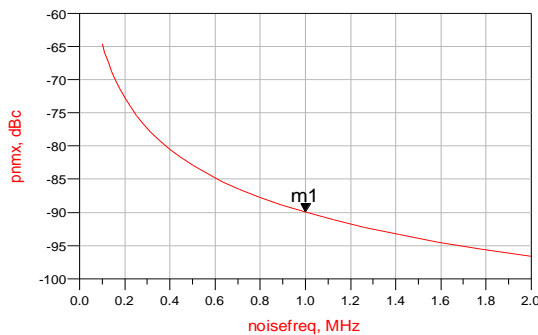

Figure 13 the phase noise of proposed oscillator

Power consumption	Frequency range	Phase noise	ref
-14 dB	1.27-4 GHz	-85 dBc/Hz	[1]
-7 dB	3.6-6.2 GHz	-78 dBc/Hz	[2]
-8.5 dB	4.7-9.3 GHz	-92 dBc/Hz	[3]
-14 dB	2-14 GHz	-90 dBc/Hz	This work

- [14] A. Daghighi and A. Neshat-Niko, "CURRENT CONTROLLED OSCILLATOR Design and Simulation Using TSMC 0.18  $\mu\text{m}$  Process to Meet IEEE802.11a Requirements," *Majlesi Journal of Electrical Engineering*, vol. 2, pp. 29-37, 2008.
- [15] S. Shieh Ali Saleh and N. Masoumi, "Wide-tuning-range, low-phase-noise quadrature ring oscillator exploiting a novel noise canceling technique," *AEU - International Journal of Electronics and Communications*, vol. 66, pp. 372-379, 2012.
- [16] Jian Zhang;Guoch Huang," SiGe V Band Wide Tuning-Range Current controlled oscillator and Frequency Divider for Phase Locked Loop", *Integrated Nonlinear Microwave and Millimetre-Wave Circuits (INMMIC)*, Sept. 2012,pp(1 – 3), E-ISBN :978-1-4673-2948-4